

KLETTENZENTRUM DAV

DAV ROCK-CLIMBING CENTRE

CENTRE D'ESCALADE DAV

KLIMCENTRUM DAV



Art. Nr. 130324

D

Vor Beginn des Bastelns sollten Sie sich mit den Spritzlingen und der Anleitung vertraut machen. Sollte es einmal vorkommen, dass ein Teil im Bausatz fehlt, kreuzen Sie bitte das fehlende Teil in der Anleitung an und schicken Sie diese bitte an Fa. Gebr. FALLER GmbH, Abt. Kundendienst, kundendienst@faller.de, Kreuzstraße 9, 78148 Gütenbach. Sie erhalten dann umgehend Ersatz. Es kann vorkommen, dass bei einem Bausatz Einzelteile übrig sind.

GB

Before beginning with the assembly please familiarize yourself with the parts and read the instructions carefully. In case of missing parts please indicate these on the instructions leaflet with a circle and return the leaflet to Gebr. FALLER GmbH, kundendienst@faller.de, Kreuzstraße 9, D-78148 Gütenbach, Germany. You will receive the replacement by return. It may happen, that in a kit single parts are not being used.

F

Avant de commencer le montage de votre maquette bien lire la notice et repérer les grappes. Si une pièce manque dans une boîte, cochez la pièce correspondante sur la notice et renvoyez-la-nous à Gebr. FALLER GmbH, kundendienst@faller.de, Kreuzstraße 9, D-78148 Gütenbach (R.F.A.). Nous vous ferons parvenir la pièce par retour. Dans certains kits, il est possible que certaines pièces ne soient pas utilisées.

NL

Vóór het bouwen zou men de gietstukken en de handleiding moeten bestuderen. Indien onverhoopt een onderdeel aan het bouwpakket ontbreekt, gelieve men het ontbrekende deel in de handleiding aan te kruisen en deze te zenden aan Gebr. FALLER GmbH, kundendienst@faller.de, Kreuzstraße 9, D-78148 Gütenbach. U ontvangt dan omgaand en gratis het ontbrekende onderdeel. Het kan voorkomen dat u bij bepaalde bouwdozen onderdelen overhoudt.

Für den Zusammenbau des Modells empfehlen wir folgende FALLER-Artikel (sind nicht im Bausatz enthalten):
For the assembly of the kit we recommend following FALLER products (not included in the kit):
Pour l'assemblage du modèle, nous vous recommandons les articles FALLER suivants (non inclus dans le kit):
Om dit model te bouwen adviseren wij de volgende FALLER producten (maken geen deel uit van deze bouwset):



Art. Nr. 170492
FALLER-EXPERT

Flüssigkleber in Plastikflasche mit Spezialkanüle für feinste Klebstoffdosierung.

Liquid cement in plastic bottle with canule for very fine dosage.

Colle liquide en bouteille plastique avec bec verseur pour un dosage précis.

Vloeibare lijm in plastic-flescon met doseerbuisje om nauwkeurig te lijmen.



Art. Nr. 170688
SPEZIAL-SEITENSCHNEIDER

zum gratfreien Abtrennen von feinsten Spritzteilen. Nur für Polystyrol geeignet.

Special side cutter for cutting off ultra-fine moulded parts without burrs. Only suitable for polystyrene.

Pince coupante spéciale pour couper sans bavure les pièces miniatures moulées par injection. Convient uniquement au polystyrène.

Speciale zijknijptang voor het braamloos afknippen van de fijnste gietstukdelen. Alleen geschikt voor polystyrol.

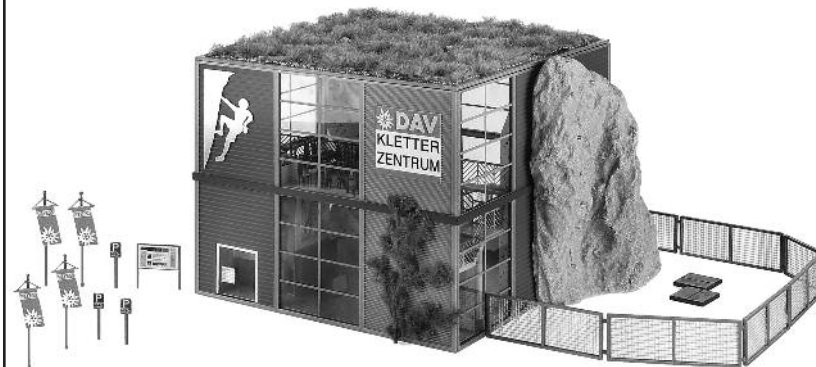

Inhalt	Spritzlinge	1 AX 1 x	4 B 1 x	7 B 1 x	26 C5 1 x
Contents	Sprues	1 AY 1 x	5 B 1 x	7 B 2 x	26 C1 7 x
Contenu	Moulages	1 B 1 x	5 B 1 x	7 D 1 x	26 C7 6 x
Inhoud	Gietstukken	2 1 x	6 B 1 x	21 AB 8 x	26 C2 10 x
		3 B 4 x	7 A 1 x	24 1 x	26 D 1 x

Sa. Nr. 130 324 1

2



(A)

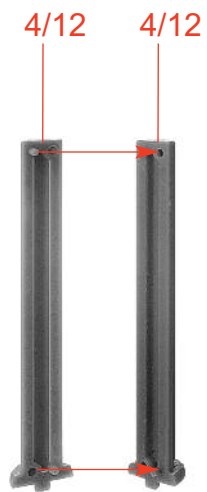

(B)

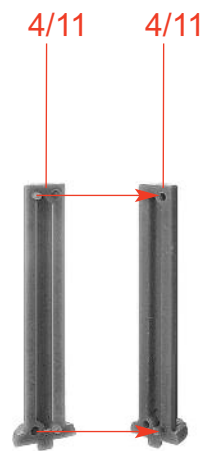

(C)

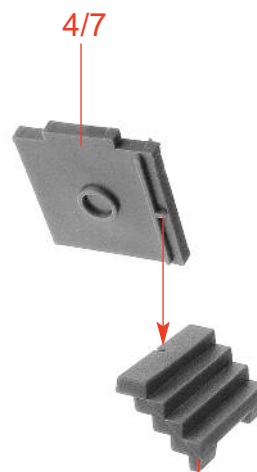

(D) 2 x

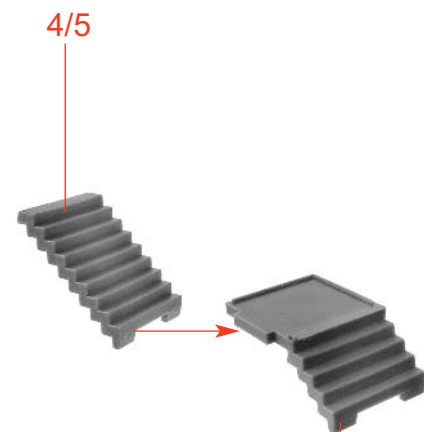

(E)

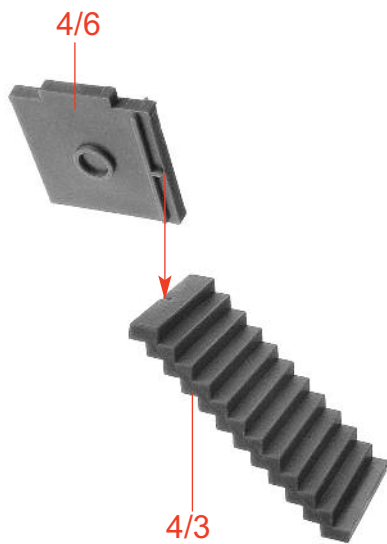

(F)

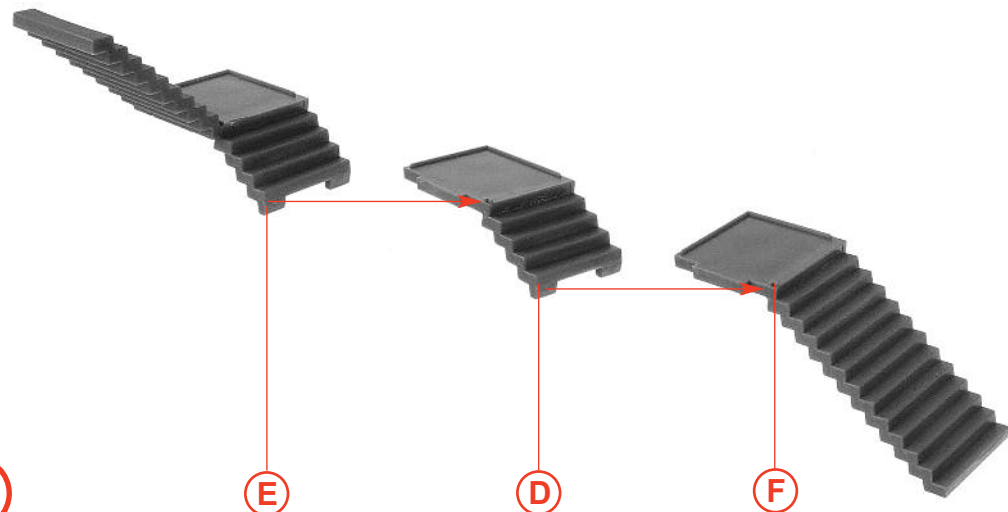

(G)

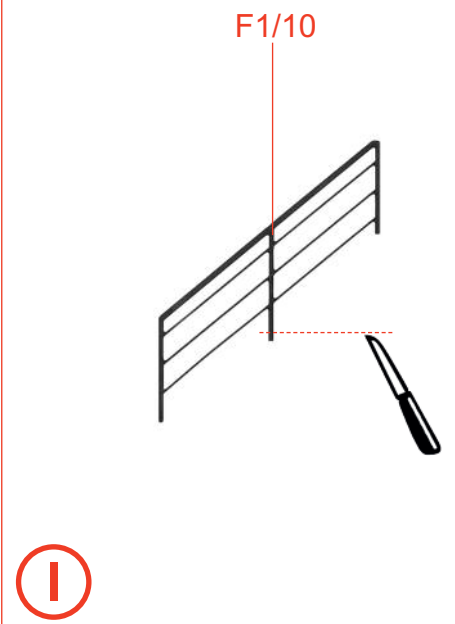
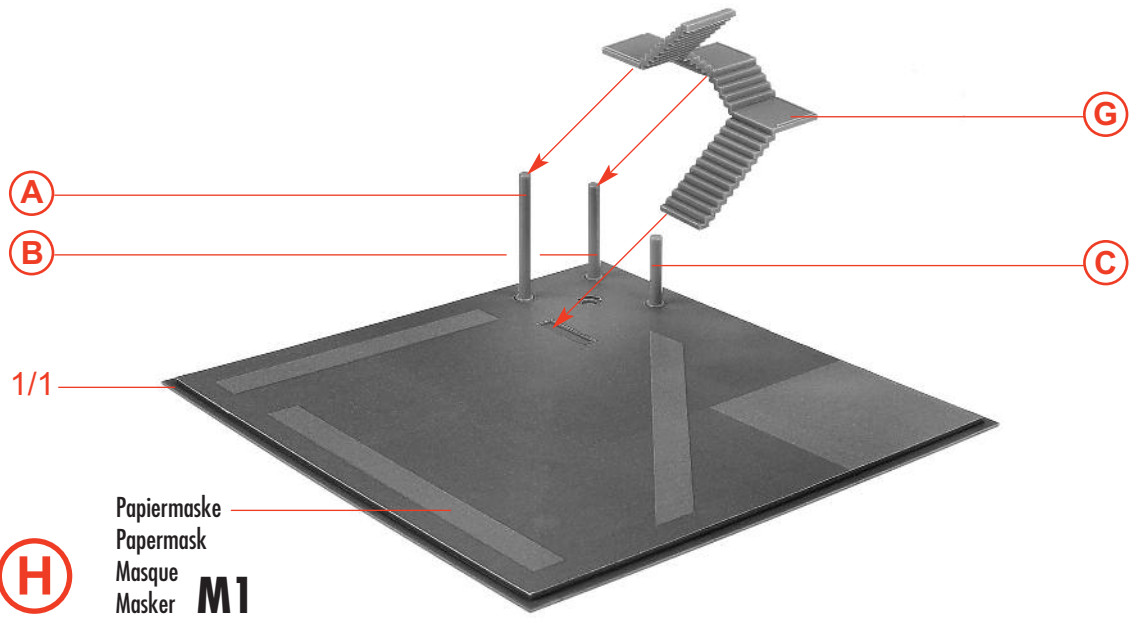

Sekundenkleber (FALLER EXPERT rapid 170500) verwenden.
Use instant modelling cement (FALLER EXPERT rapid 170500).
Utilisez la colle rapide (FALLER EXPERT rapid 170500).
Gebruik secondenlijm (FALLER EXPERT rapid 170500).

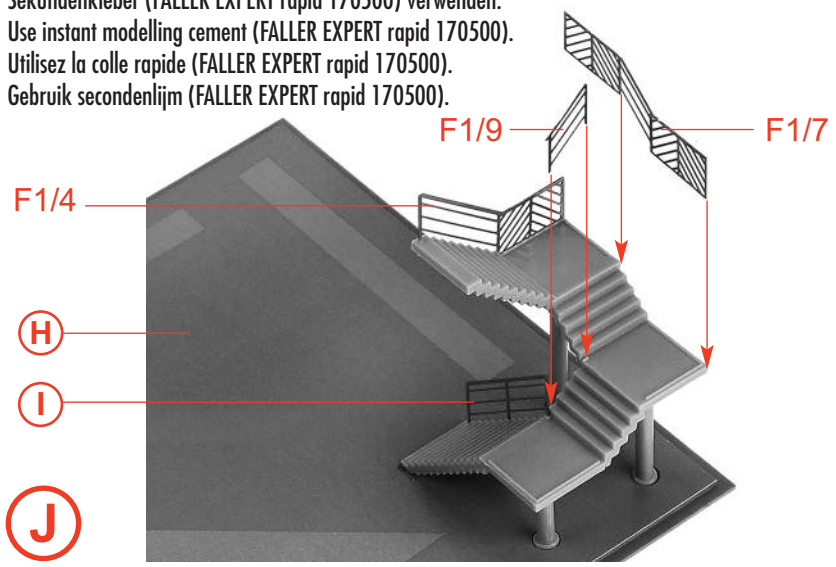

Sekundenkleber verwenden.
Use instant modelling cement.
Utilisez la colle rapide.
Gebruik secondenlijm.

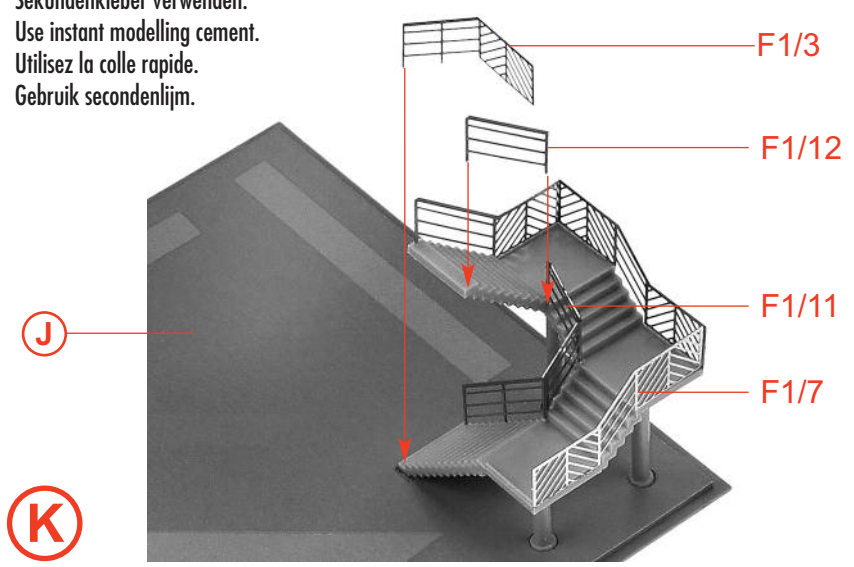

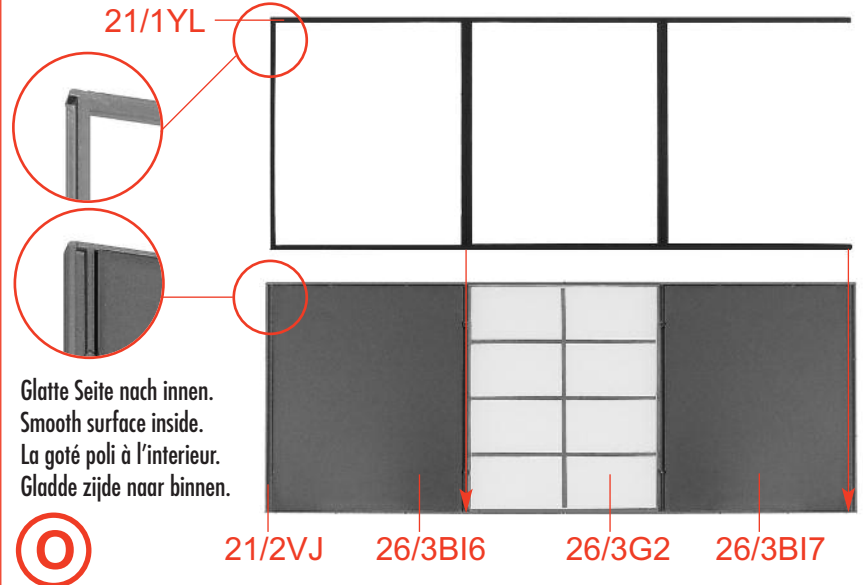
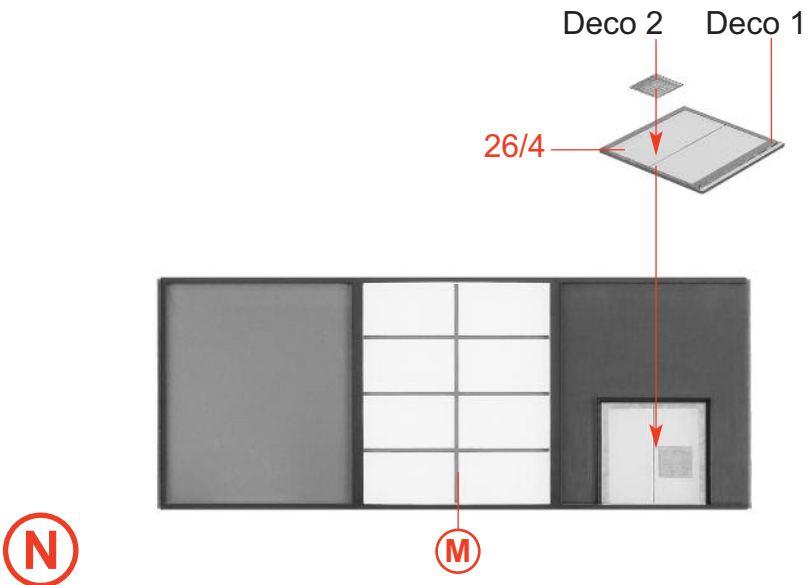
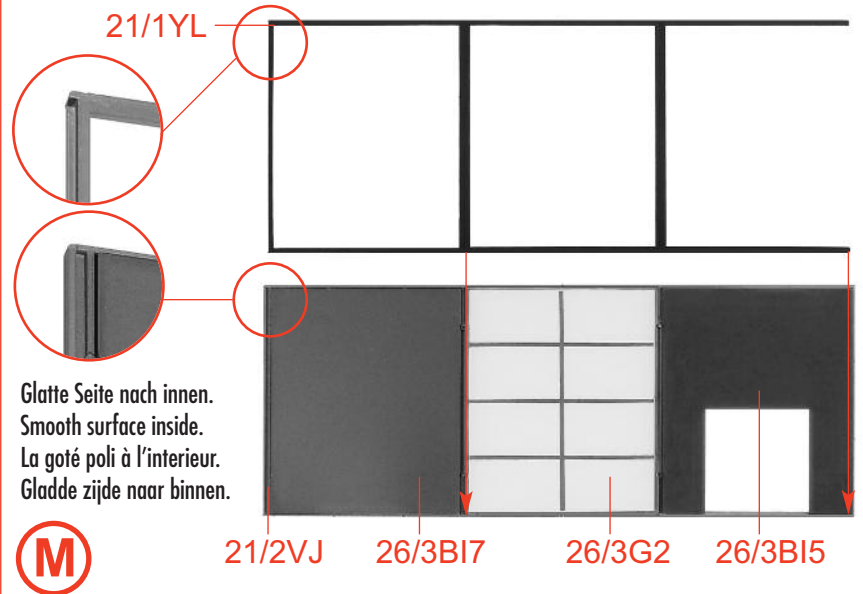
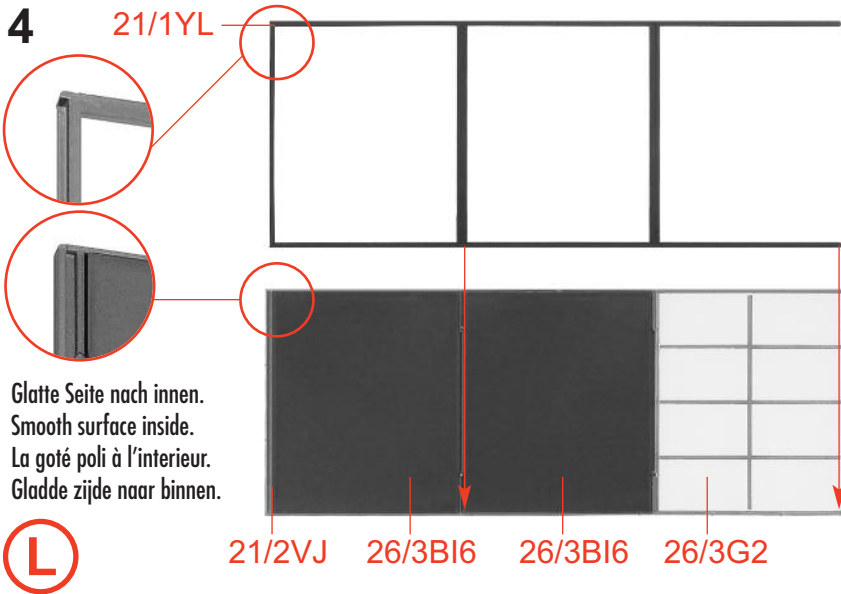

21/1YL

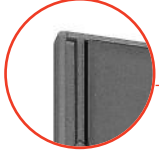

Glatte Seite nach innen.
Smooth surface inside.
La goté poli à l'intérieur.
Gladde zijde naar binnen.

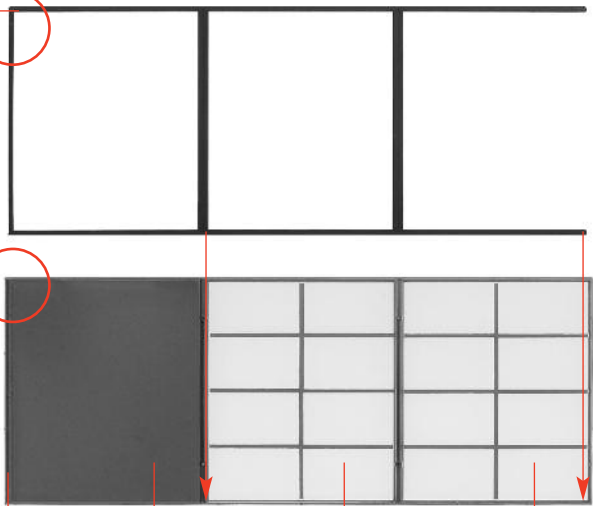

P

21/2VJ 26/3BI7 26/3G2 26/3G2

P

D7/19

Q

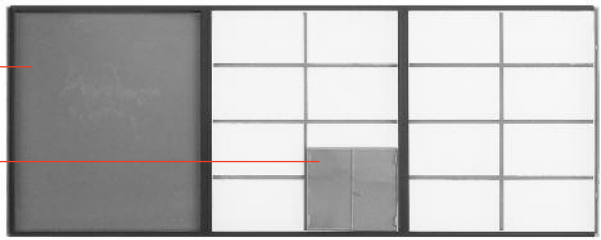

Q

D7/19

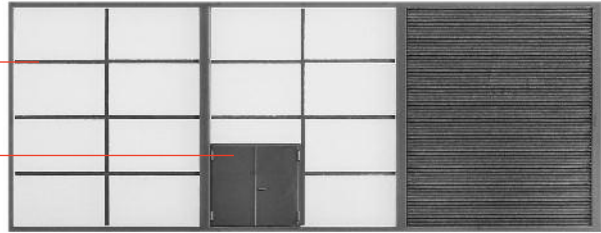

R

L

N

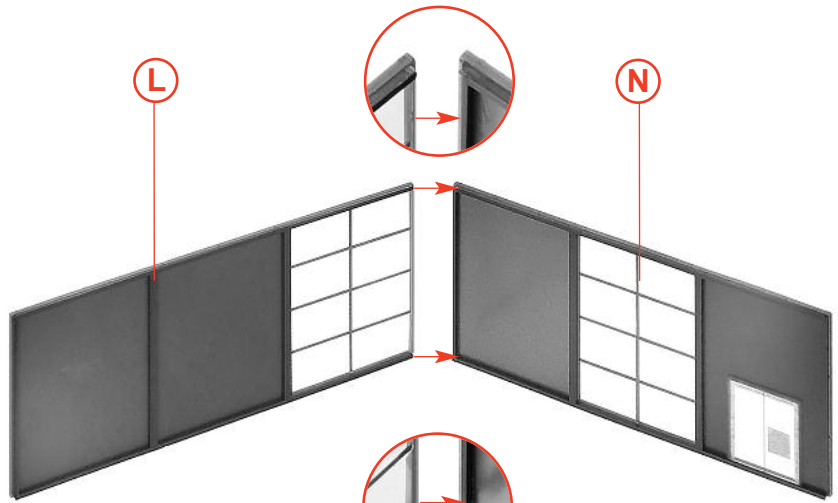

S

K

S

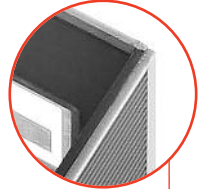

T

R

O

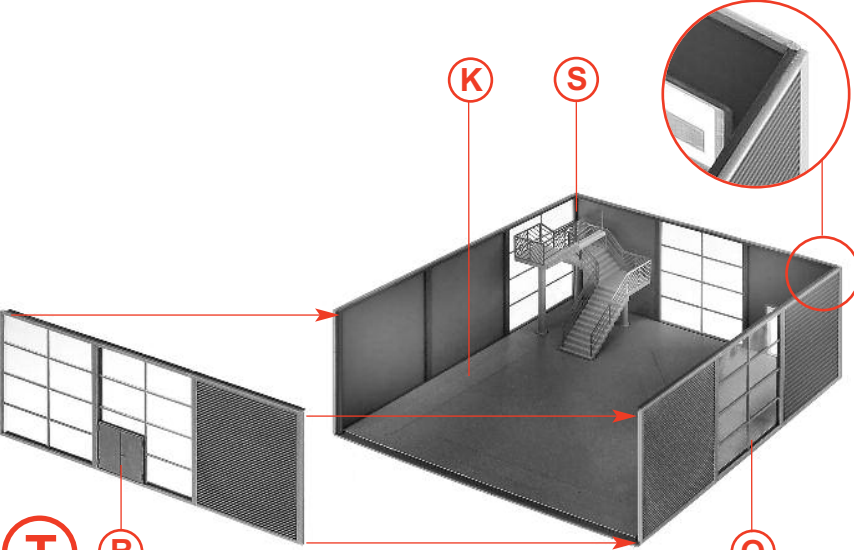

6

B7/20

Deco 5

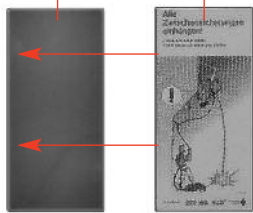

U 2 x

B7/20

Deco 4

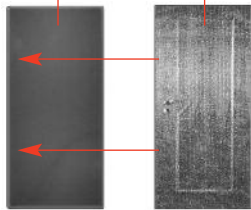

V 3 x

Deco 3



W rot red rouge rood B7/7

Deco 7 Deco 6

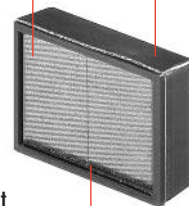

X rot red rouge rood B7/10

4/8 4/8



Y

Papiermaske
Papermask
Masque
Masker M2

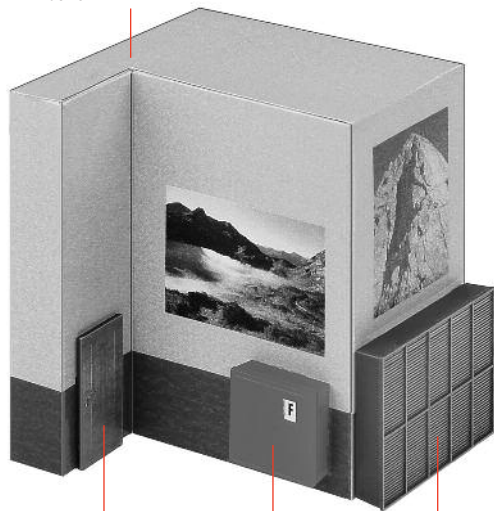

Z

V

W

A7/6

U

U

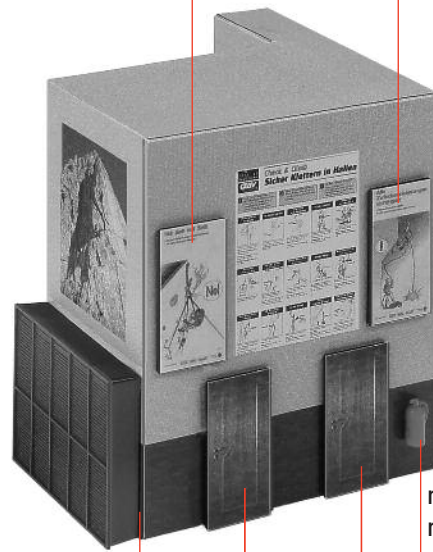

a

Z

V

V

rot red rouge rood B7/6

Y 5/5 X a

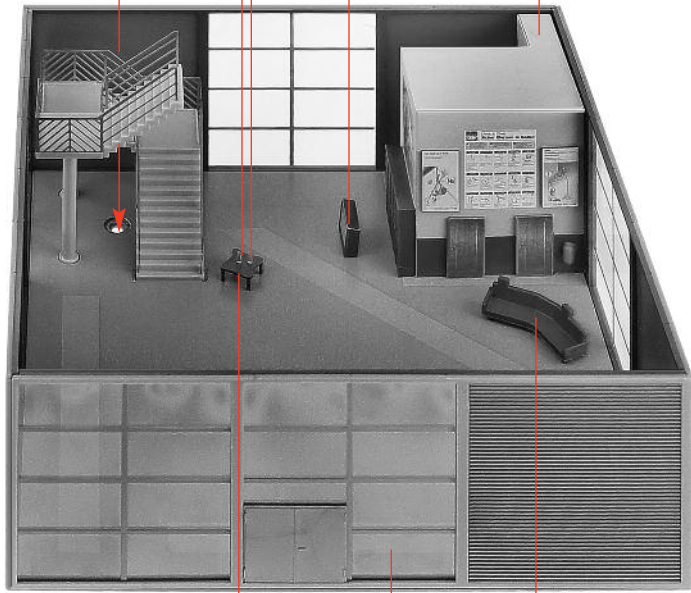

b

B7/15

T

A7/3

c

Papiermaske
Papermask
Masque
Masker **M3**

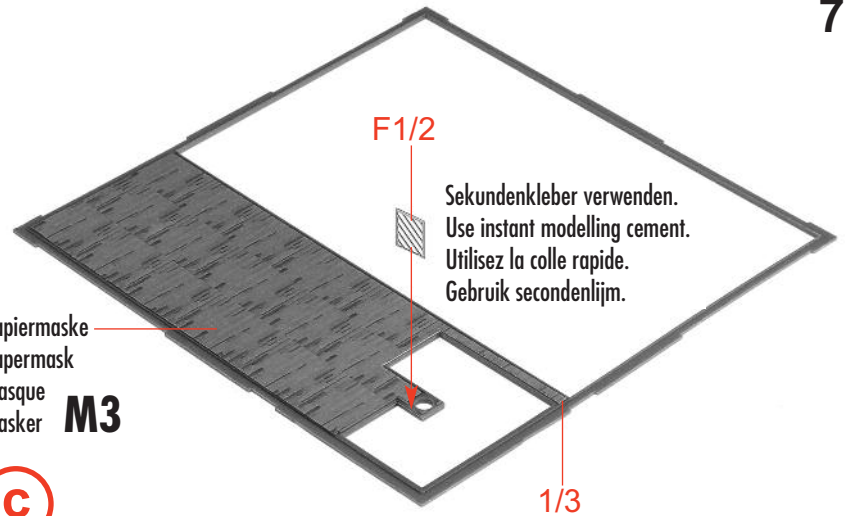

F1/2

Sekundenkleber verwenden.
Use instant modelling cement.
Utilisez la colle rapide.
Gebruik secondenlijm.

1/3

d

F1/5

F1/5

F1/1

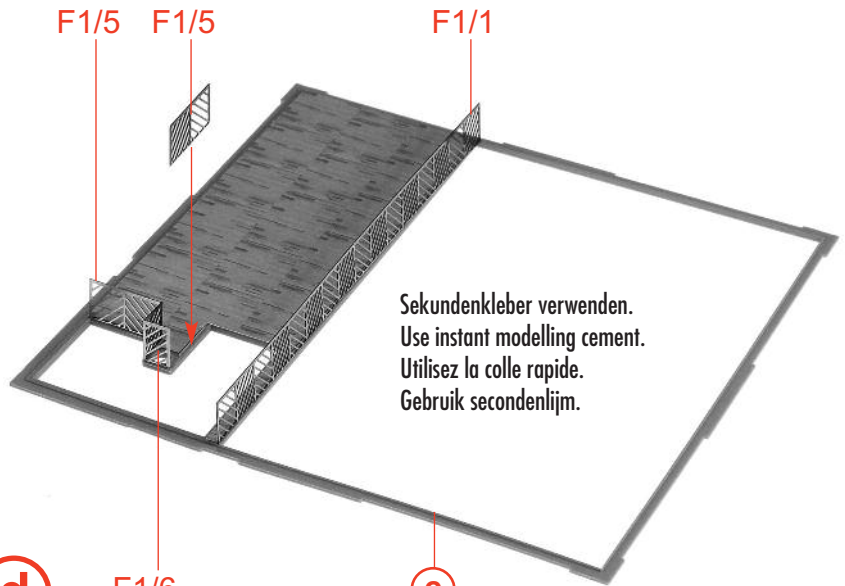

Sekundenkleber verwenden.
Use instant modelling cement.
Utilisez la colle rapide.
Gebruik secondenlijm.

F1/6

c

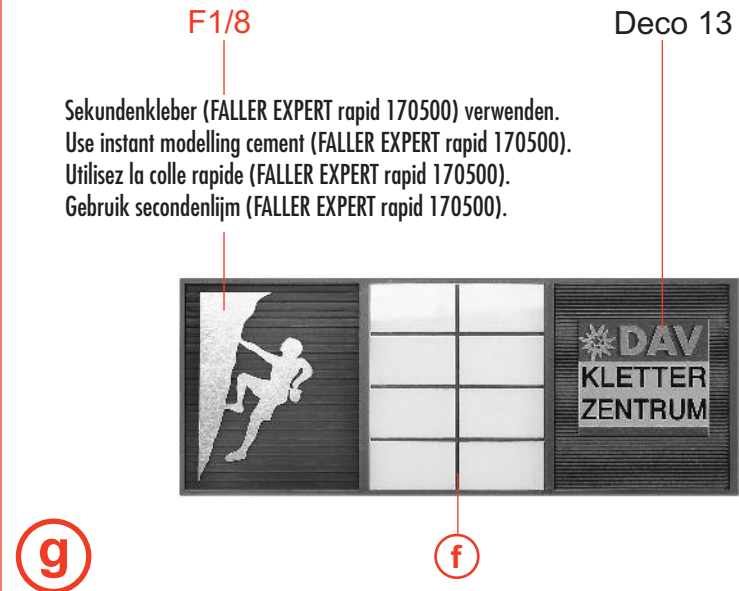
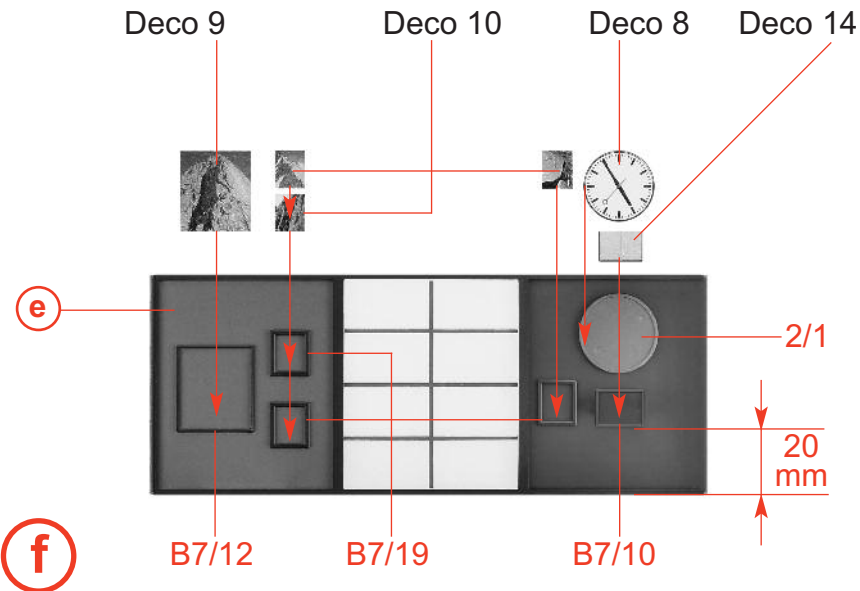
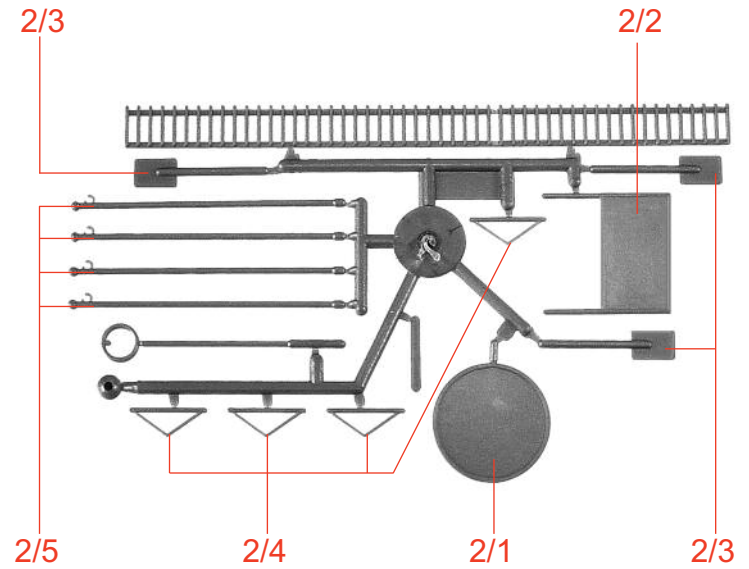
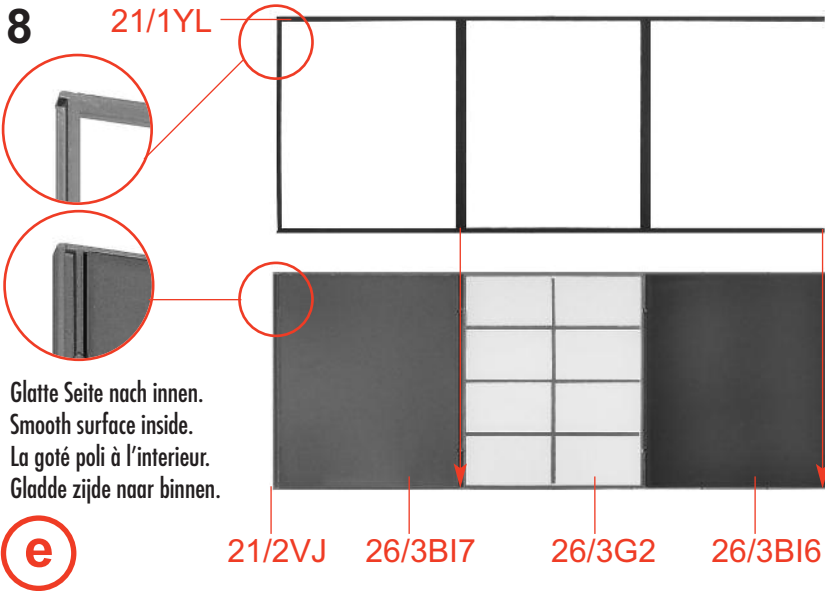

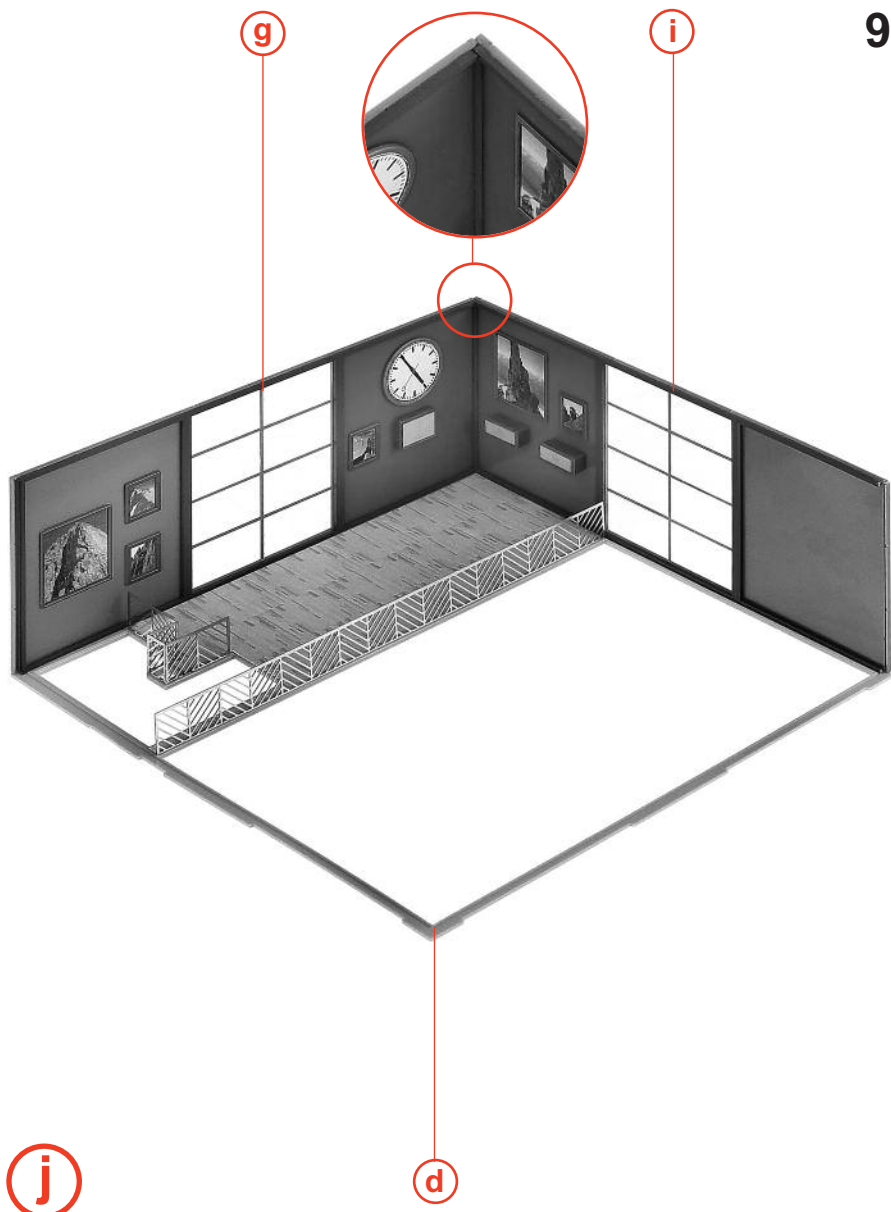
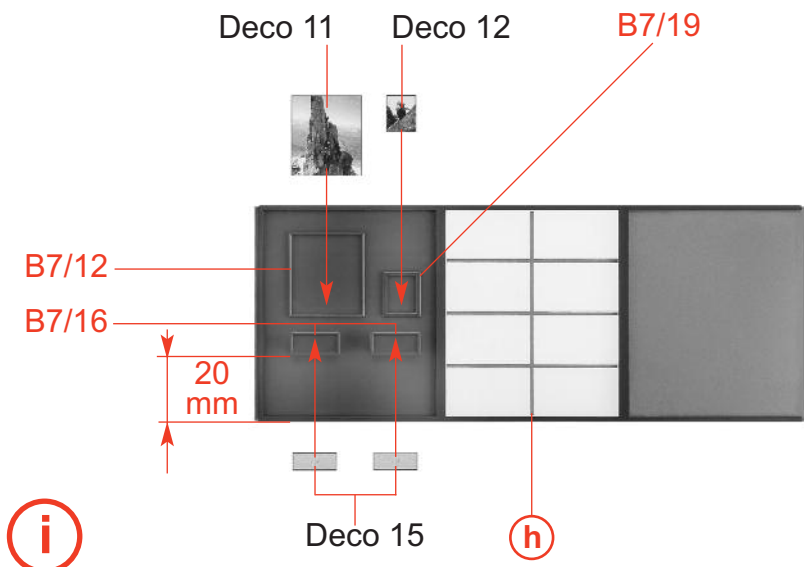
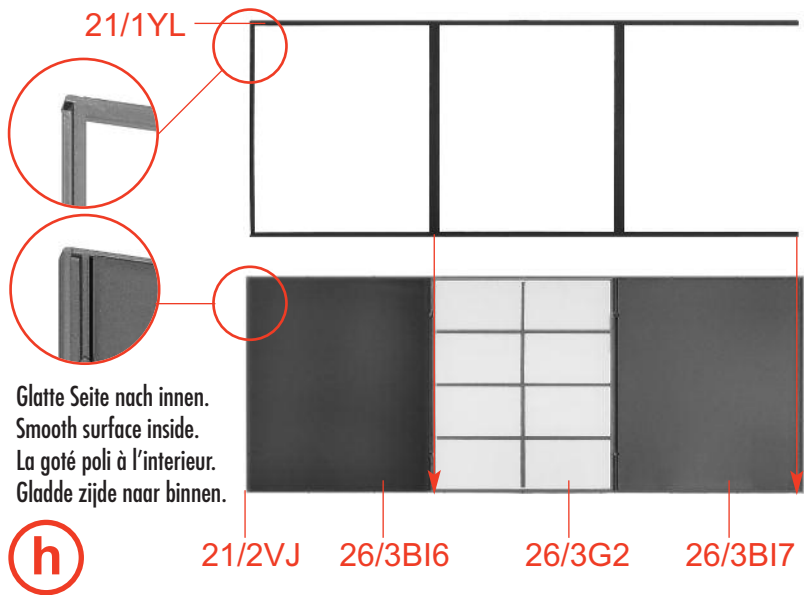

10

Deco 16

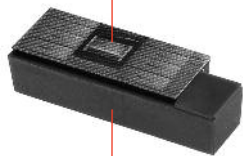

6/24

(k)

Deco 17

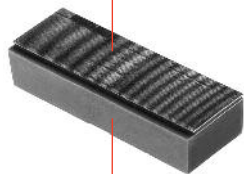

6/25

(l)

A7/1

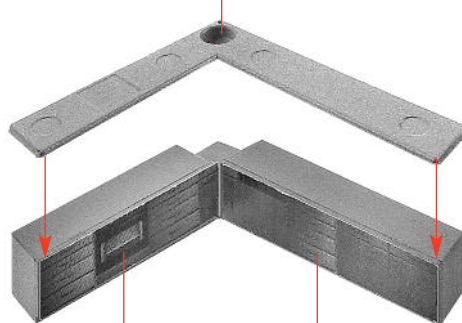

(m)

(k)

(l)

Deco 19 5/7+5/8

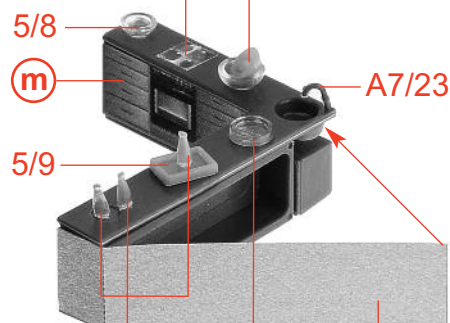

5/8

(m)

5/9

(n)

5/5

5/10

Deco 20

Deco 18

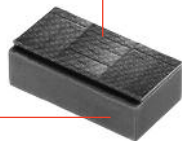

6/23

(o)

5/5

Deco 23

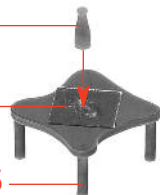

(r)

B7/15

A7/2

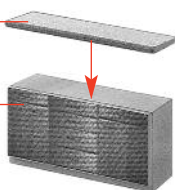

(p)

Deco 15

Deco 15

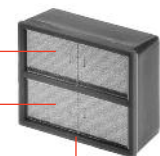

(s)

2 x

B7/17

5/5

5/7

(p)

Deco 21

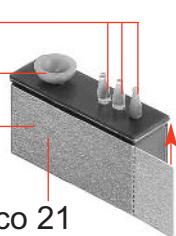

(q)

5/10

5/6

5/6

(t)

(s)

B7/21

2 x

B7/21



(t)

B7/6

(n)

5/9

A7/5

A7/4

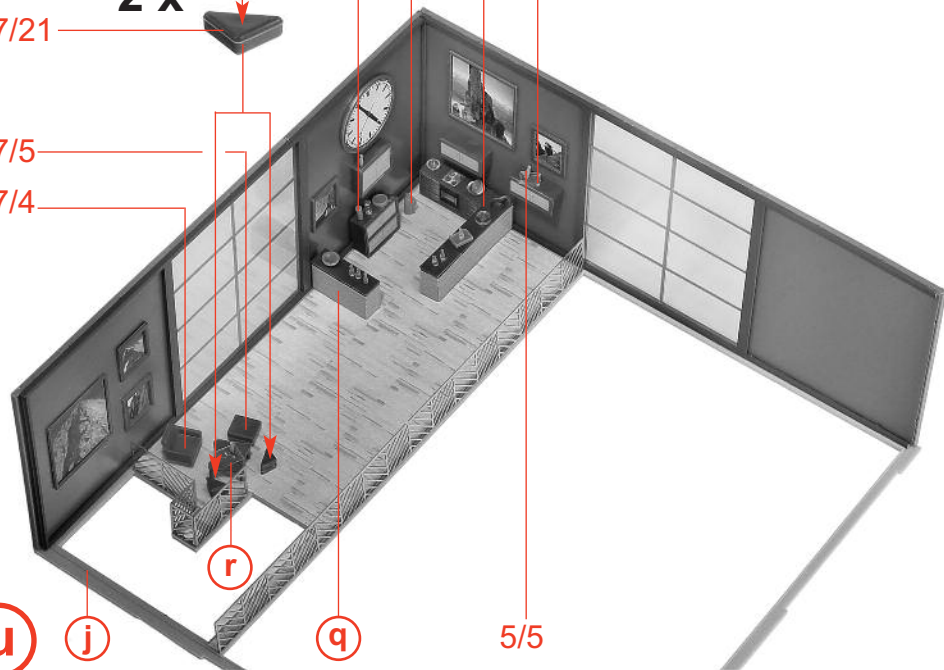

(u)

(j)

(r)

(q)

5/5

21/1YL

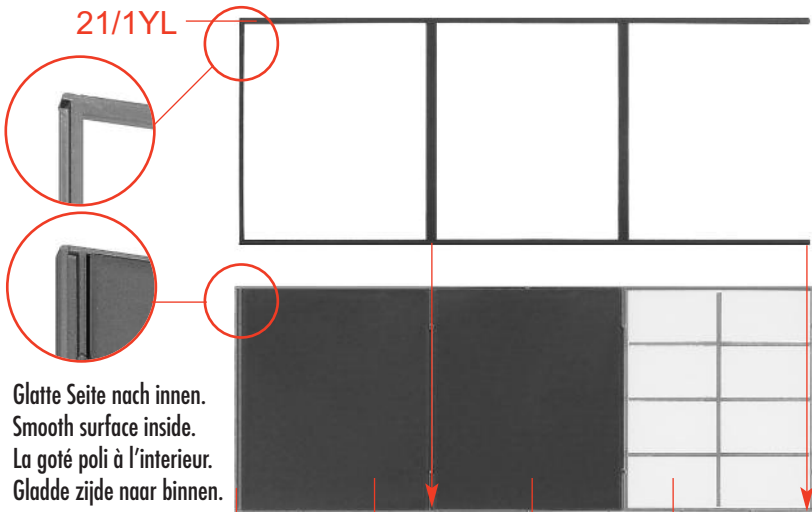

V

21/2VJ 26/3BI6 26/3BI6 26/3G2

21/1YL

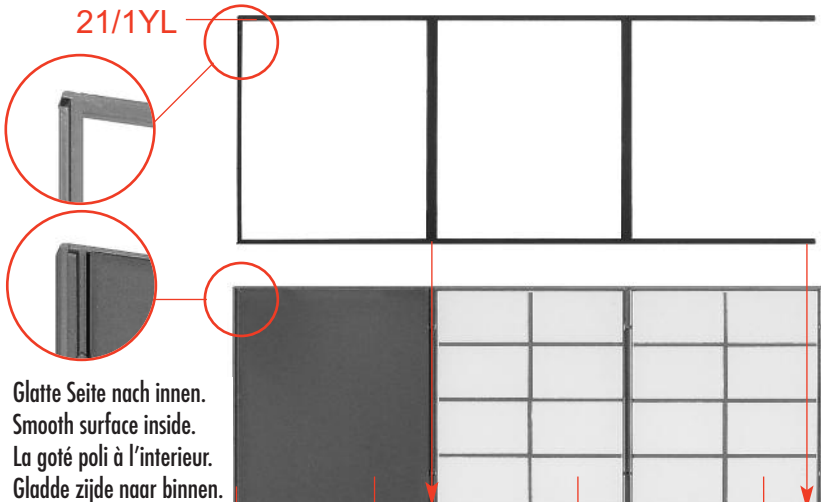

W

21/2VJ 26/3BI7 26/3G2 26/3G2

B7/14 B7/13



X 12 x

Deco 22



6/21

Y 3 x

Deco 24



Z 2 x 6/20

5/5 **11**

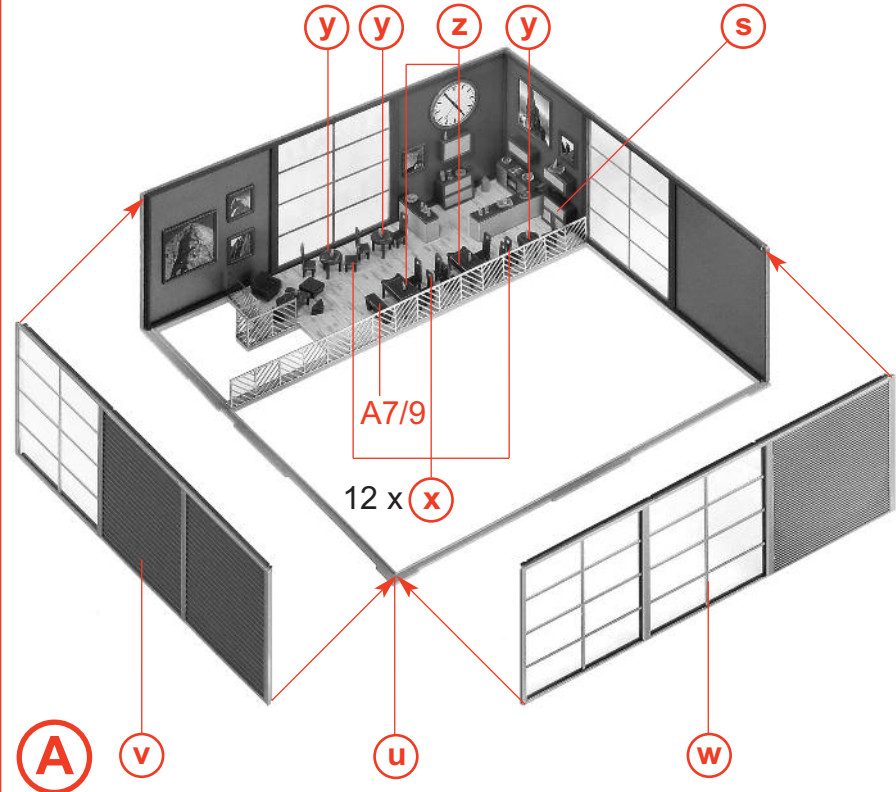

12 Inhalt Tüte Contents bag
 Contenu sachet Inhoud zakje

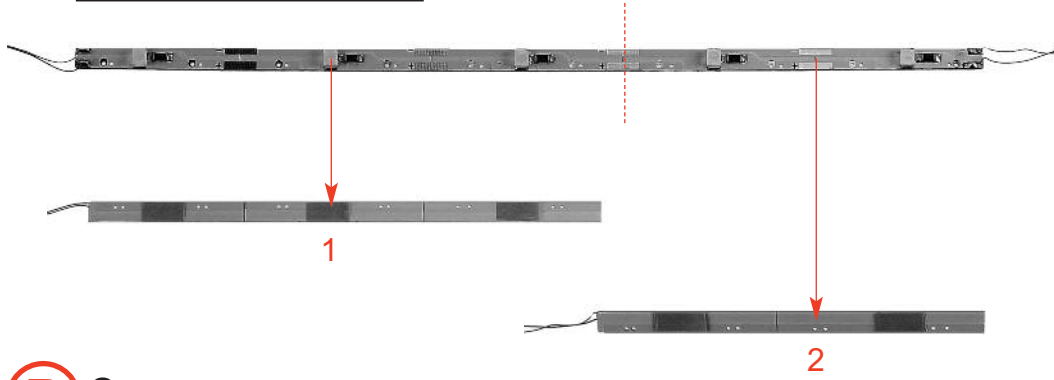

(B) 2 x

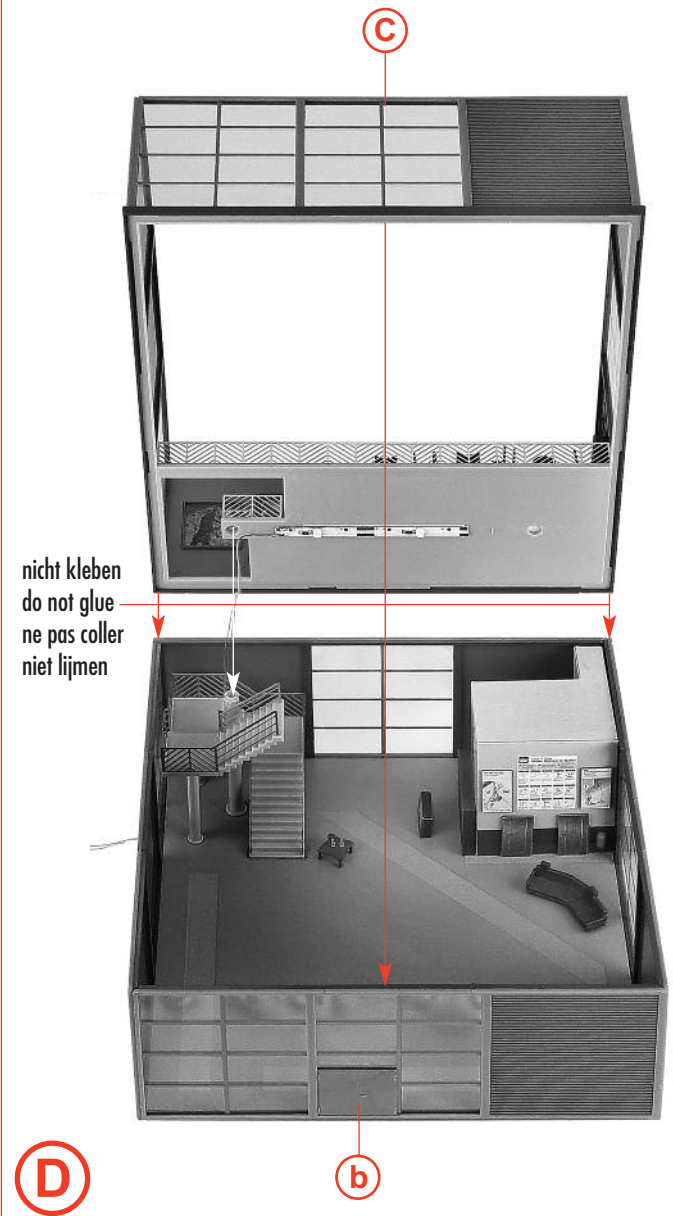
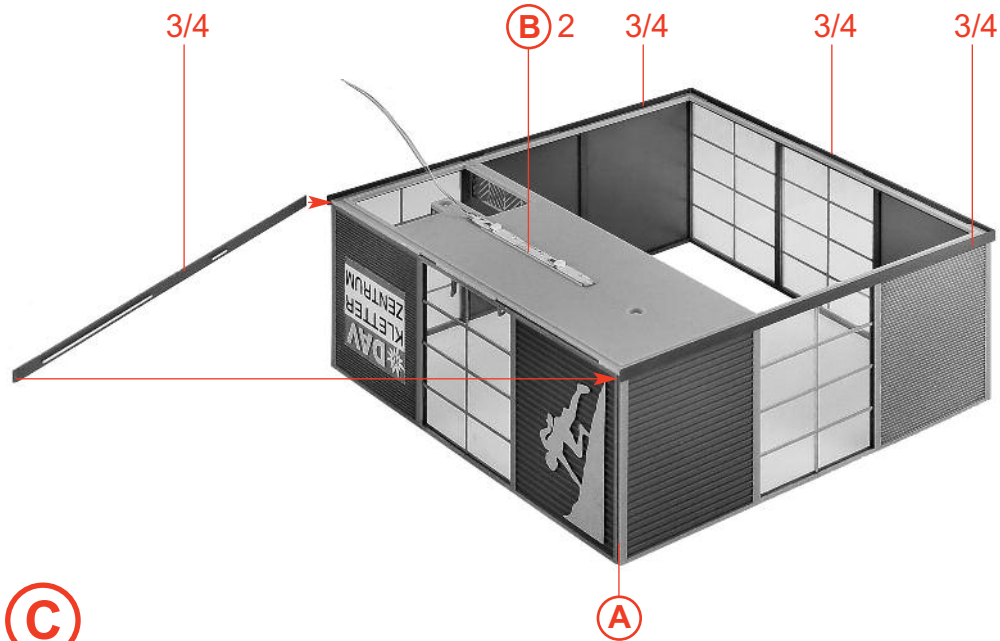

Papiermaske
Papermask
Masque
Masker **M4**

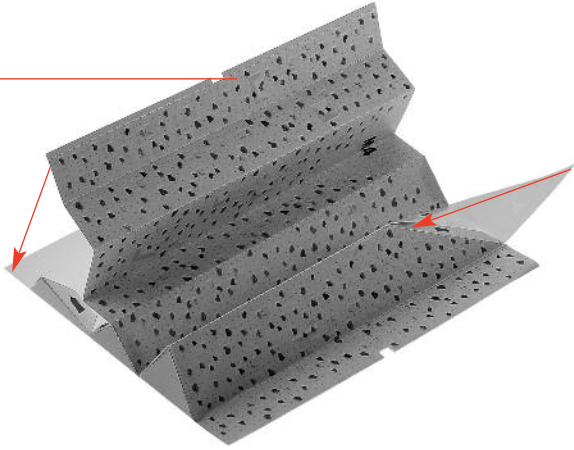

E

Papiermaske
Papermask
Masque
Masker **M5**

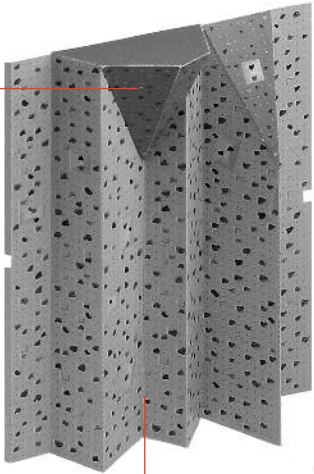

F

E

F



G

D

14

Papiermaske
Papermask
Masque
Masker **M9**

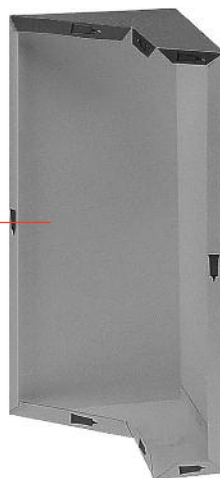

H

Papiermaske
Papermask
Masque
Masker **M7**

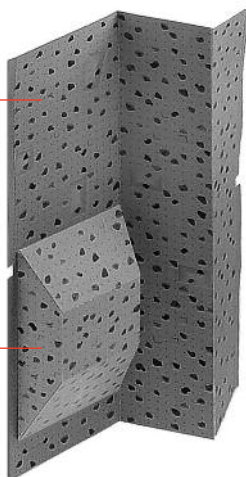

Papiermaske
Papermask
Masque
Masker **M8**

I

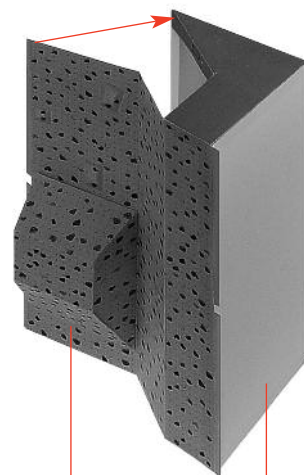

J

I

H

K

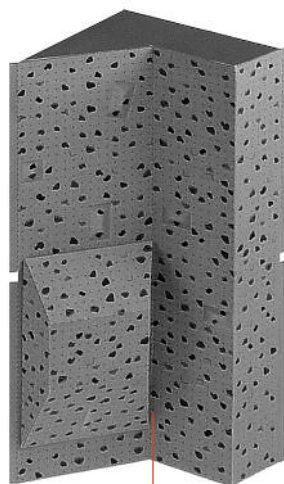

J

L

K



G

Papiermaske
Papermask
Masque
Masker **M6**

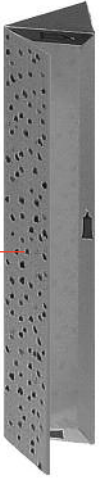

M



N

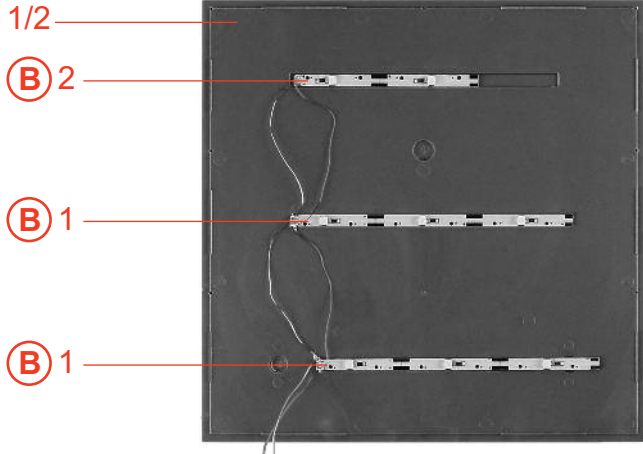

O

Kupferlackdraht abisolieren und verlöten.
Enamelled copper wire strip and solder.
Fil de cuivre émaillé dénuder et souder.
Printplaat strip en soldeer.

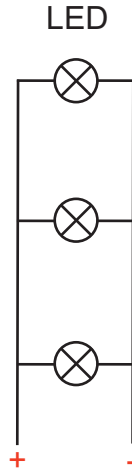

nicht kleben
do not glue
ne pas coller
niet lijmen

N

M

P

O

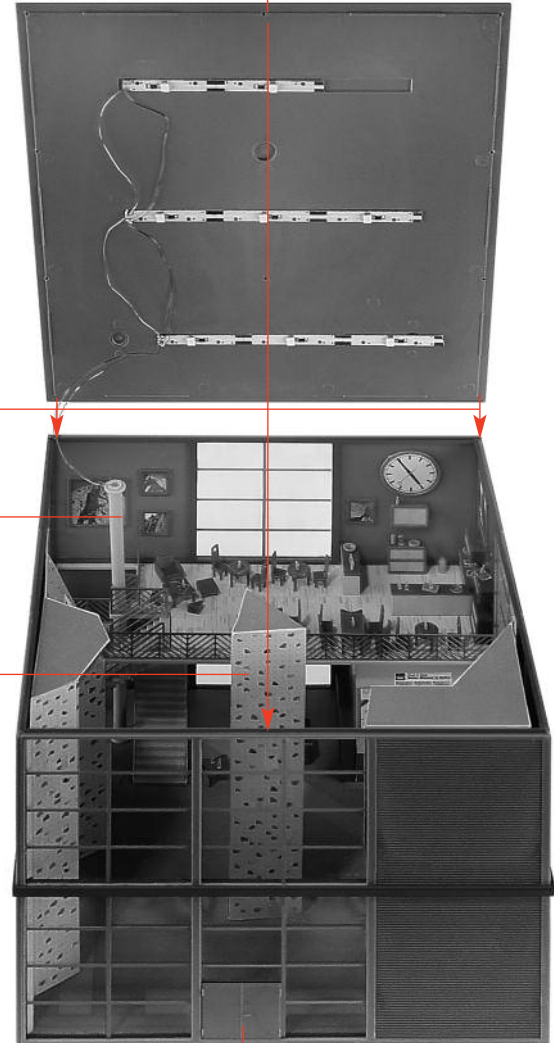

L

Spannungsversorgung: 12-16 V, Wechsel-/ Gleichspannung

Stromaufnahme: pro LED- Lichterkette ca. 60 mA

Anschluss der LED an Wechselspannung: Ein Kabel an den linken 16 V, AC Anschluss klemmen und das andere an den rechten 16 V, AC Anschluss klemmen.

Anschluss der LED an Gleichspannung: Das rote Kabel an den 12 V, DC Anschluss klemmen. Das andere Kabel an den 0 V (Masse) Anschluss klemmen.

Für einen flackerfreien Betrieb bei Wechselspannung benötigen Sie den Gleichrichter 180633.

Achtung: Lichtleisten nur auf einer Seite anschließen.

Die Lichtleisten können **einmalig** im **spannungsfreien Zustand** an den vorgegebenen Stellen geteilt werden und getrennt voneinander betrieben werden.

Zur Befestigung der Leisten liegen beidseitige Klebestreifen bei.

Power supply: 12-16 V, AC/DC

Power consumption: per strip of LED fairy lights approx. 60 mA

To connect the LED to AC power: clamp one cable to the left 16 V, AC terminal and the other to the right 16 V, AC terminal.

To connect the LED to DC power: clamp the red cable to the 12 V, DC terminal. Clamp the other cable to the 0 V (earth) terminal.

In AC voltage mode you need rectifier 180633 for a flicker free operation.

Caution: connect spotlight on one side only.

The strips of fairy light can be split **once** in a **voltage-free state** at the specified places and operated separately from each other.

Double-sided adhesive strips are provided to attach the strips of fairy lights.

Alimentation électrique : 12-16 V, courant alternatif/courant continu

Courant absorbé : 60 mA env. pour une guirlande lumineuse à LED

Raccordement des LED à une source de courant alternatif: Brancher un câble au raccordement 16 V, CA gauche et l'autre au raccordement 16 V, CA droit.

Raccordement des LED à une source de courant continu: Brancher le câble rouge au raccordement 12 V, CC. Brancher l'autre câble au raccordement 0 V (terre).

Pour un fonctionnement correct sous courant alternatif, utiliser le redresseur réf 180633.

Attention: Ne raccorder la rampe d'éclairage que d'un seul côté.

Les rampes de guirlandes lumineuses peuvent être divisées **une fois** aux endroits donnés lorsqu'elles sont **hors tension** et fonctionner séparément les unes des autres.

Des rubans adhésifs double face sont fournis pour fixer les rampes de guirlandes lumineuses.

Spanningstoevoer: 12-16 V, wissel-/ gelijkstroom

Stroomopname: per LED-keten ca. 60 mA

LED op wisselstroom aansluiten: Sluit één kabel aan op de linker 16 V, AC-aansluiting en de andere kabel op de rechter 16 V, AC-aansluiting.

LED op gelijkstroom aansluiten: Sluit de rode kabel aan op de 12 V, DC-aansluiting. Sluit de andere kabel aan op de 0 V-aansluiting (massa).

Om bij gebruik van wisselstroom lichtflikeringen te vermijden heeft u de gelijkrichter 180633 nodig.

Let op: lichtstrips mogen slechts aan één zijde worden aangesloten.

De lichtstrips kunnen **eenmalig** in **spanningsvrije toestand** op de aangegeven punten worden gedeeld en gescheiden van elkaar worden gebruikt.

Ter bevestiging van de lichtstrips zijn dubbelzijdige plakstroken bijgevoegd.

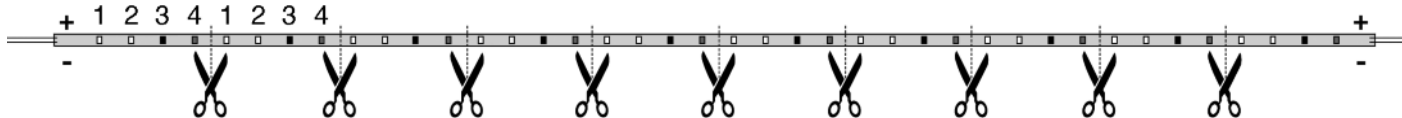

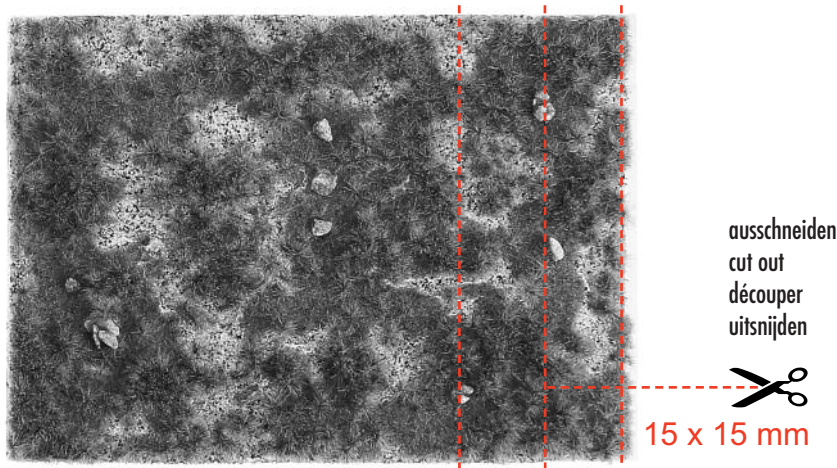

Q

150 x 165 mm



150 x 15 mm

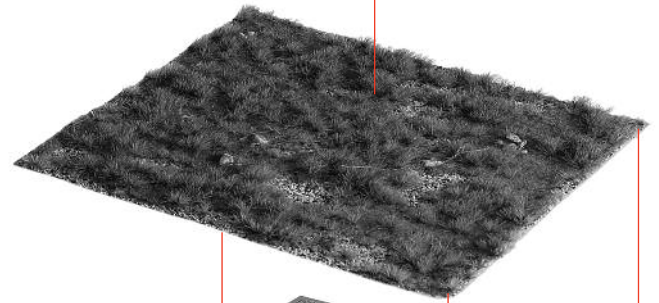

Art.-Nr. 170659
liegt nicht bei
not included
non jointe
niet bijgevoegd

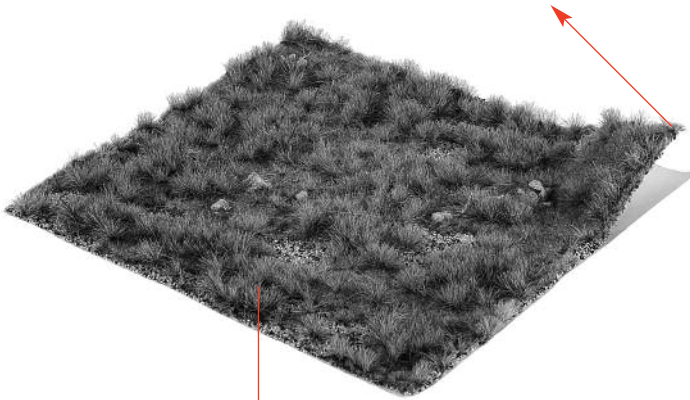
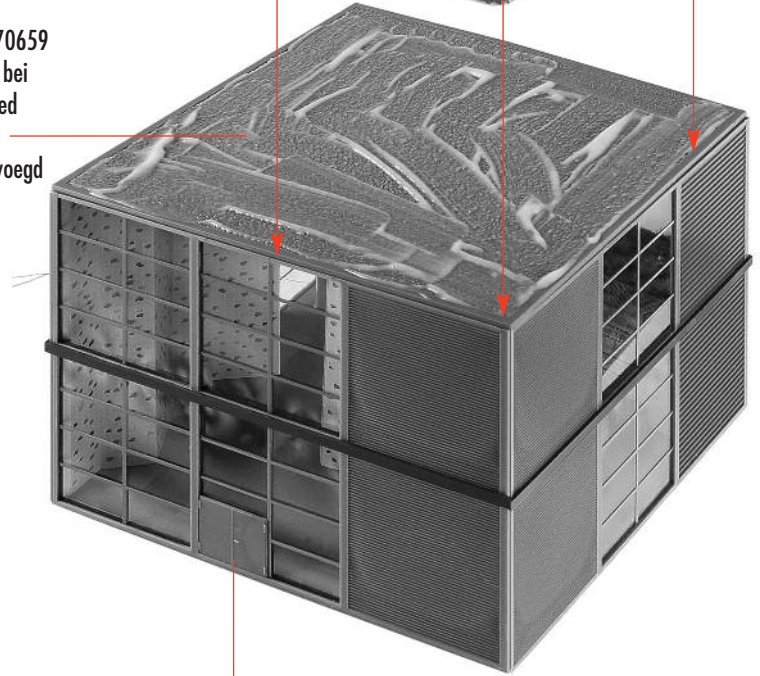

Q

150 x 165 mm

R

S

P

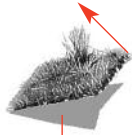

Q 15 x 15 mm

T



Q 150 x 15 mm

U

Klebestelle gut abtrocknen lassen!
 Allow glue joints to dry well!
 Laisser bien sécher les points de collage!
 Alle gelijmde punten goed laten drogen!

U

T

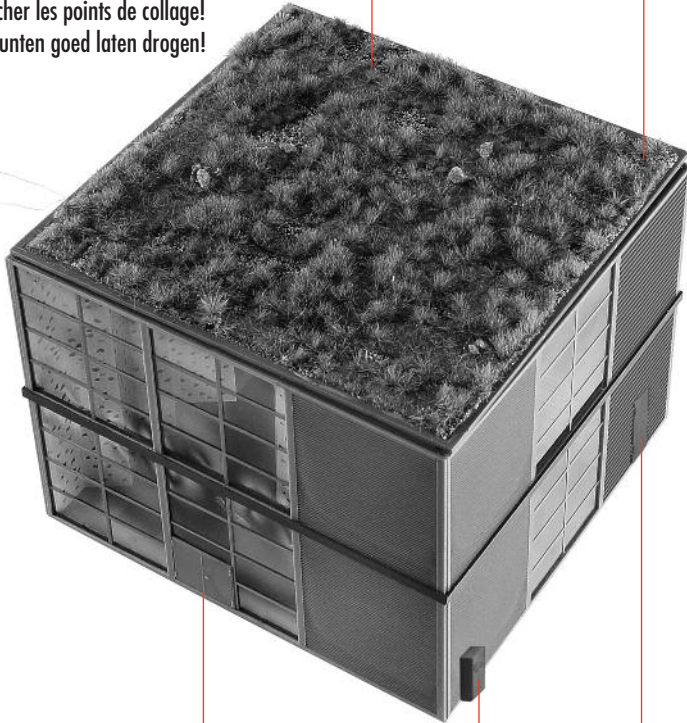

V

S

D7/20

D7/18

Mit Alleskleber kleben
 Use all-purpose glue
 Utiliser de la colle universelle
 Met een universele lijm lijmen

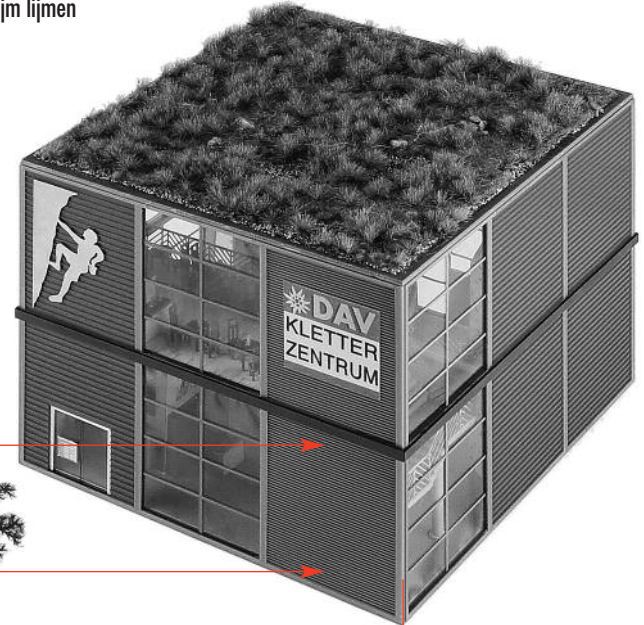
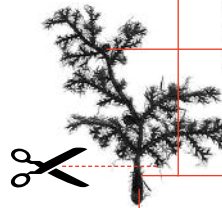

W

Inhalt	Tüte	Contents	bag
Contenu	sachet	Inhoud	zakje

V

10 Löcher mit Ø 0,9 mm bohren.
 Drill 10 holes with a dia. of 0,9 mm.
 Percer 10 trousés avec un Ø 0,9 mm.
 10 gaten met Ø 0,9 mm boren.

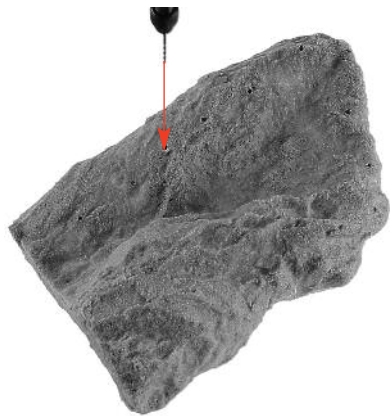

X

ausschneiden
 cut out
 découper
 uitsnijden

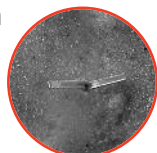

ausschneiden
 cut out
 découper
 uitsnijden

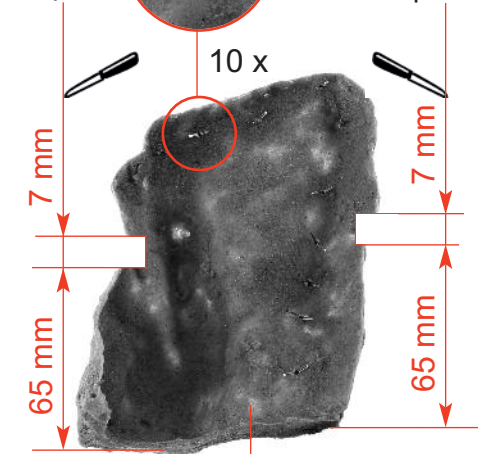

Z

Y

Inhalt	Tüte	Contents	bag
Contenu	sachet	Inhoud	zakje

Gitter
 Grille

Grill
 Tralie

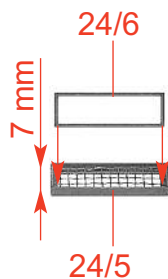

A

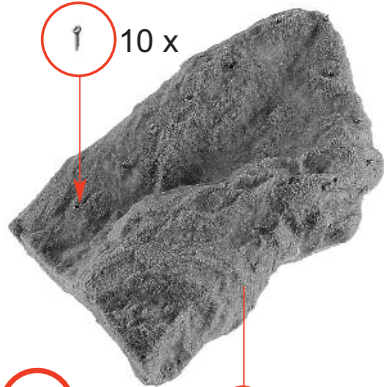

y

x

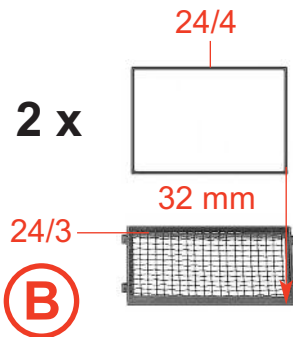

B

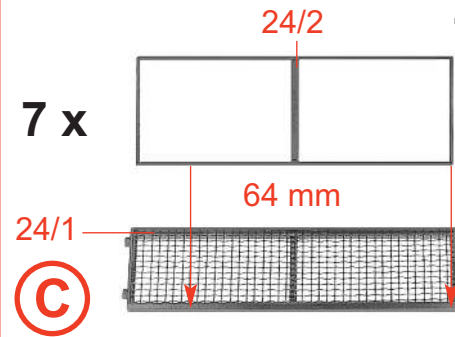

C

19

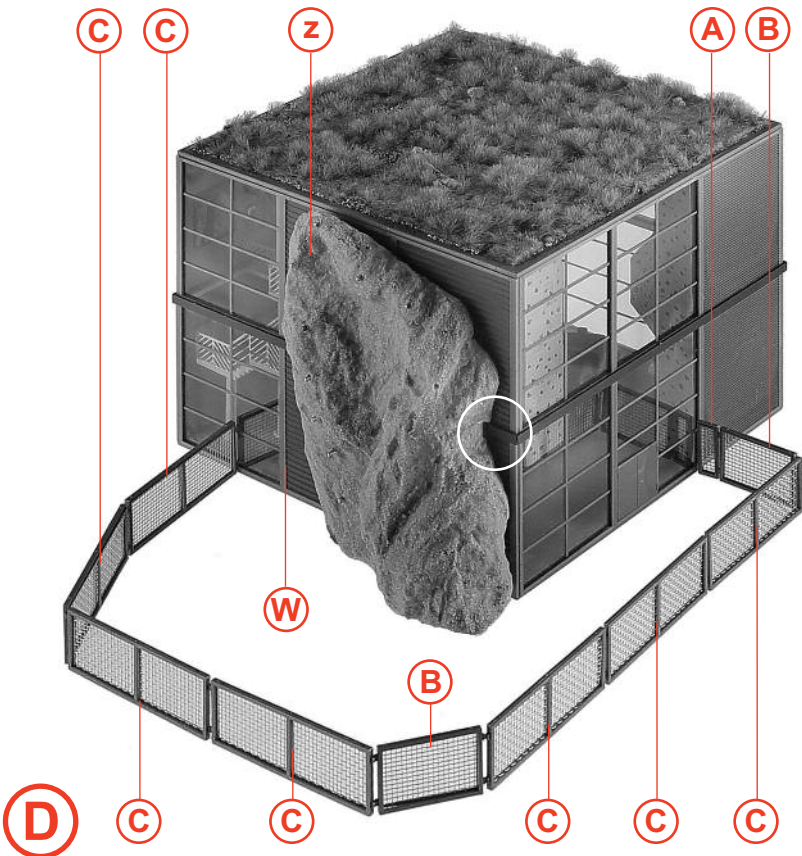

20

Deco 27



E 3 x 2/3

Deco 26



F 2/2

Deco 26

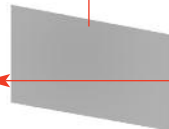

Deco 25

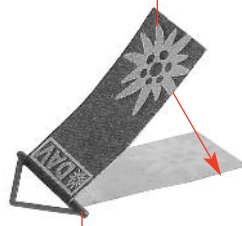

G 4 x 2/4

G



2/5

H 4 x

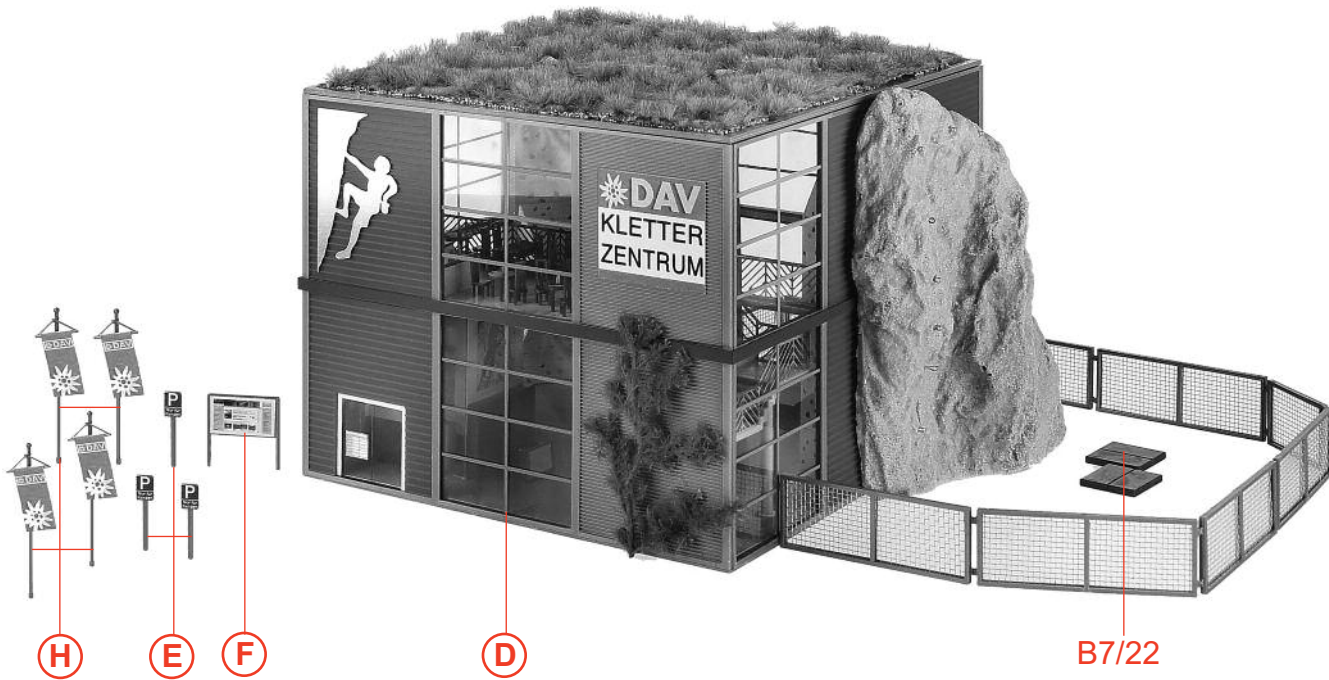

I

H

E

F

D

B7/22